

Assembly instructions for the exhibition stand I123

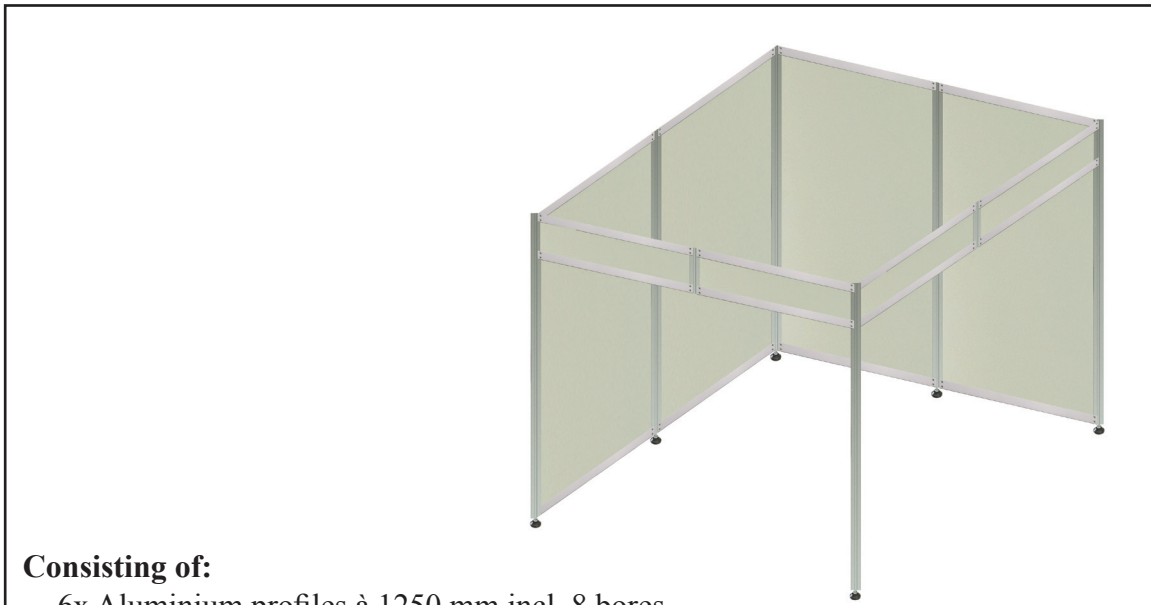

Consisting of:

- 6x Aluminium profiles à 1250 mm incl. 8 bores
- 6x Aluminium profiles à 1250 mm incl. 8 bores and adjustable feet
- 2x Aluminium profiles à 300 mm incl. 8 bores for fascia sign frame
- 8x Aluminium cross profiles with pointed screws for the lower and upper mounting
- 8x Aluminium cross profiles with pointed screws for fascia sign frame
- 16x H-profiles à 1217 mm to stabilize the panels
- 4x PVC rigid foam panels à 952 x 2446 mm
- 4x PVC rigid foam panels à 952 x 246 mm
- 6x Extension bolts for aluminium profile
- 3x Longarm spotlights 450 mm incl. bulb

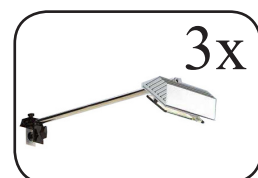
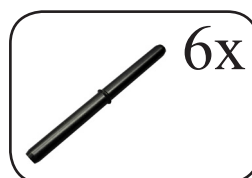
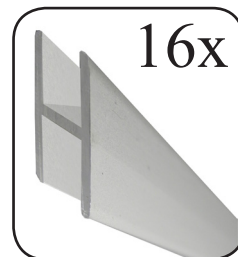
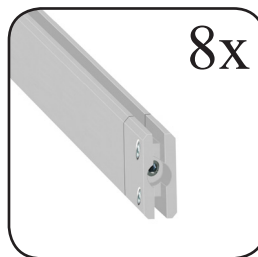
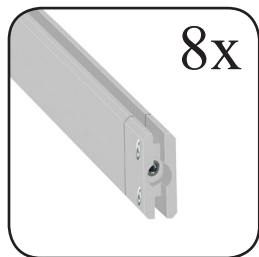
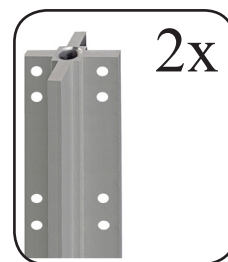
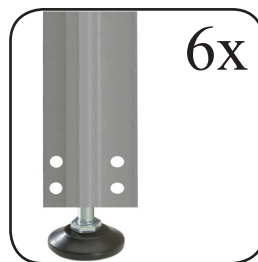
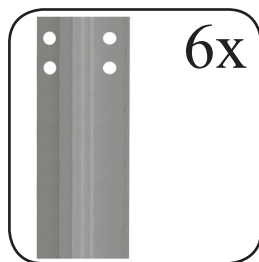

Important

Pointed screws must be used for all profiles with screw holes.

1. Mount the bottom cross profiles including the pointed screws to form the corner and insert the bolts in the profile.

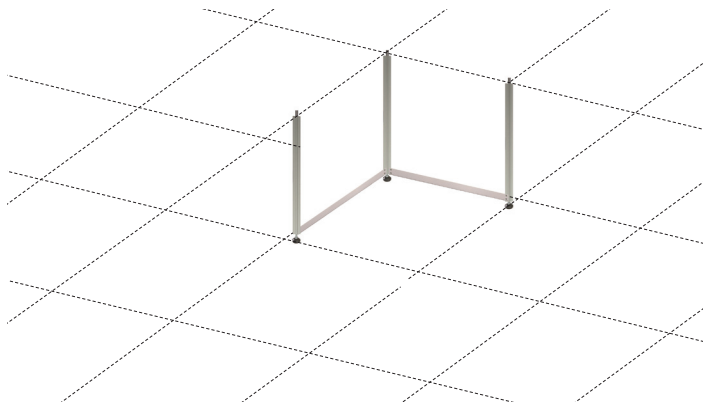

2. Push the top profiles onto the bolts. Ensure that the holes face upward.

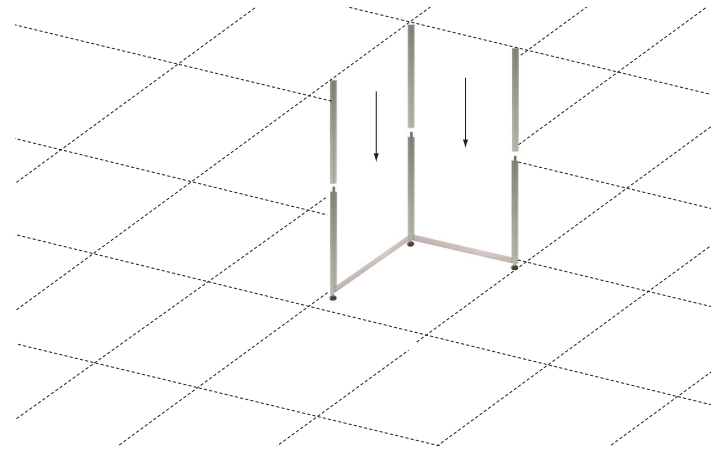

3. Insert the panels with the H-profiles and then mount the cross profiles including the pointed screws.

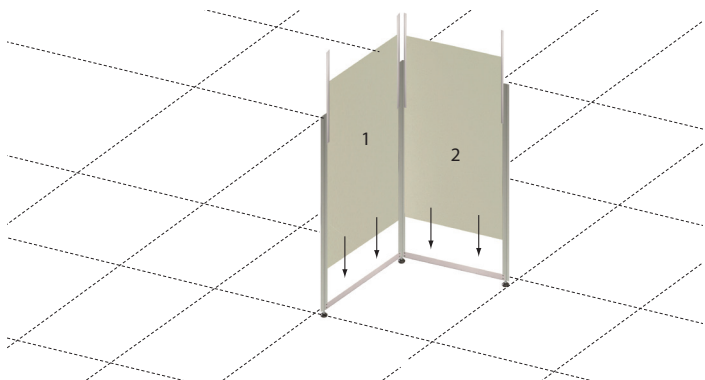

4. Mount the required lower cross profiles including pointed screws.

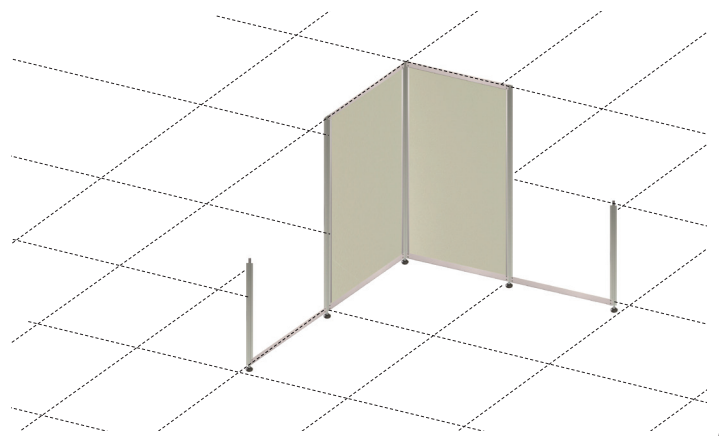

5. Insert the bolts in the profile and push the top profiles onto the bolts. Ensure that the holes face upward.

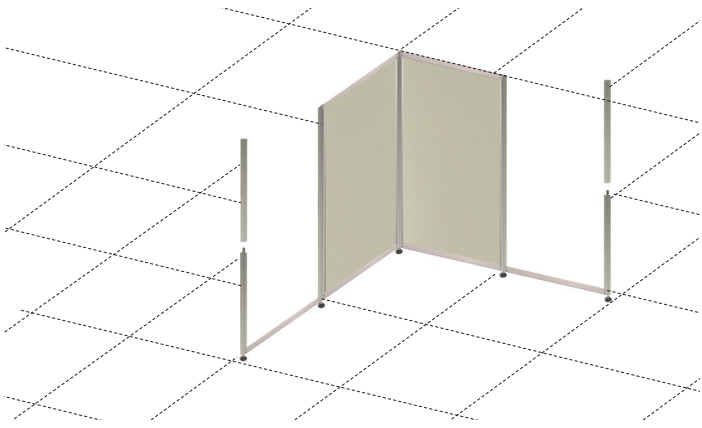

6. Insert the panels with the H-profiles and then mount the cross profiles including the pointed screws.

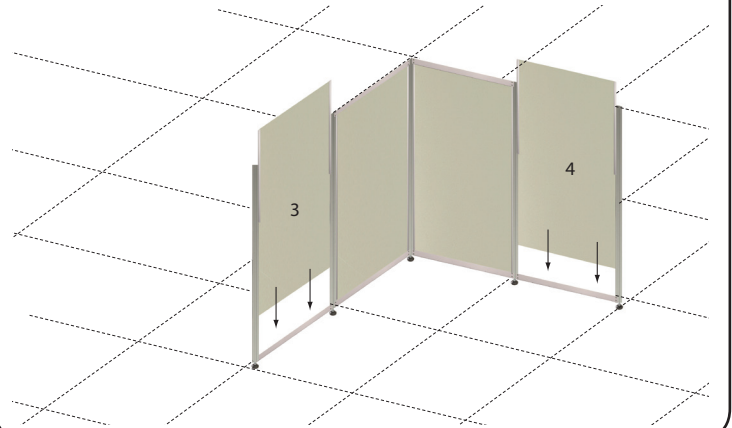

7. Then mount the first part of the fascia sign frame

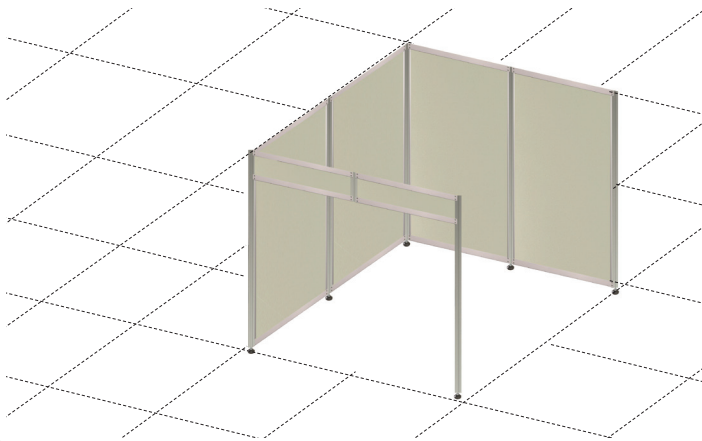

8. Then mount the rest of the fascia sign frame. If necessary, use the adjustable feet to compensate for unevenness in the floor.

